



**Naturally CLAY.**  
A facade from  
nature.



**ARCHITECT** | DI Lothar Huber Architects, Lustenau, AT

**OBJECT** | Pertinsel children's house, Fussach, AT

**PRODUCT** | TONALITY® Facades (BAS-Flex)

**COLOUR** | Cream, Pearl grey & special color

**SURFACE** | smooth

**PHOTOGRAPHY** | Günter Laznia, Bregenz, AT

# Content.

## THE COMPANY

- 4 A future with a history
- 6 A facade tile is conquering the world

## THE CERAMIC FACADE

- 10 Overview & Systems
- 12 Advantages of ceramic facades

## REFERENCE PROJECTS

- 16 The Wave Apartments, Denmark
- 20 Vesalius Residential Complex, Belgium
- 24 Data Centre Office, Canada
- 28 Maggie's Centre, United Kingdom
- 32 Toowong Train Station, Australia
- 36 Forfatterhuset Kindergarten, Denmark

## INDIVIDUALITY & COLOUR

- 42 Surfaces & Forms
- 46 Nature Collection
- 48 Color Collection

## SUSTAINABILITY AND VISION

- 52 Our environmental philosophy
- 54 Improving construction

TONALITY AND LEIPFINGER-BADER

## A future with a history – a facade tile is conquering the world.

For over 15 years TONALITY has stood for individuality, consistent quality and convincing product variety. Thanks to the takeover by LEIPFINGER-BADER, synergies can be created in the future which ideally complement the strategic orientation of the company.

TONALITY products are already being used all over the world.  
A unique tile from the Westerwald for unique buildings.





**ARCHITECT** | HDR Rice Daubney, Sydney, AU  
**OBJECT** | Chris o'Brien Lifehouse, Camperdown, AU  
**PRODUCT** | TONALITY® Facades  
**COLOUR** | Cream light, Pearl grey, Flint grey  
**SURFACE** | smooth



## Setting the tone for the future.

### A FACADE TILE IS CONQUERING THE WORLD

It all begins with an excellent raw material: it is found in the Westerwald region, which are known for having the largest and highest quality clay deposits in Europe. And in the centre of this region, at a manufacturing facility with over 150 years of ceramic tradition, we have been producing the popular TONALITY facade ceramics since 2004. We can obtain the Westerwald clay we need for this directly from pits in the immediate vicinity and process it with very short transport routes. Thanks to modern technology, committed employees and our many years of know-how, our facade tiles are thus created in the heart of nature – for projects all over the world.



**WESTERWALD**

TONALITY GmbH  
In der Mark 100  
D-56414 Weroth



# The rear-ventilated ceramic facade



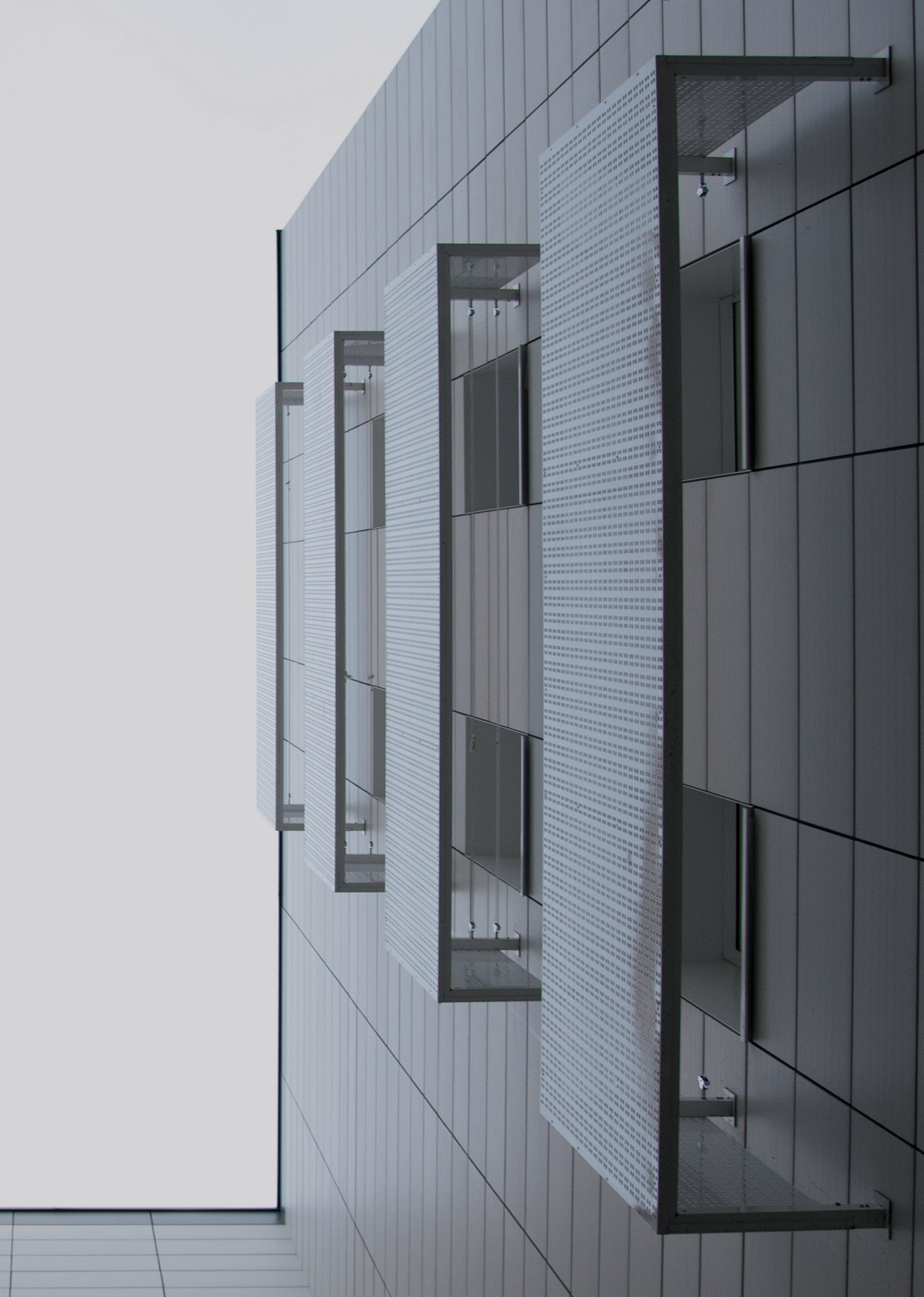

# The rear-ventilated ceramic facade.



## PRINCIPLE OF THE SUSPENDED, REAR-VENTILATED FACADE

The suspended, rear-ventilated facade is a highly effective system due to the physical separation of insulation and weather protection. Due to the space between the cladding material and the insulation, air can circulate behind the facade cladding and remove any moisture. In terms of cost-effectiveness, ecology and durability, the suspended, rear-ventilated facade is gaining in importance as a superior system in new construction and renovation. This system can be used for almost all building types and heights. The suspended, rear-ventilated facade system helps to reduce energy costs and fully complies with the requirements for energy-saving facades. Through the use of adequate insulation thicknesses, the suspended, rear-ventilated facade can achieve low-energy and passive house standards.

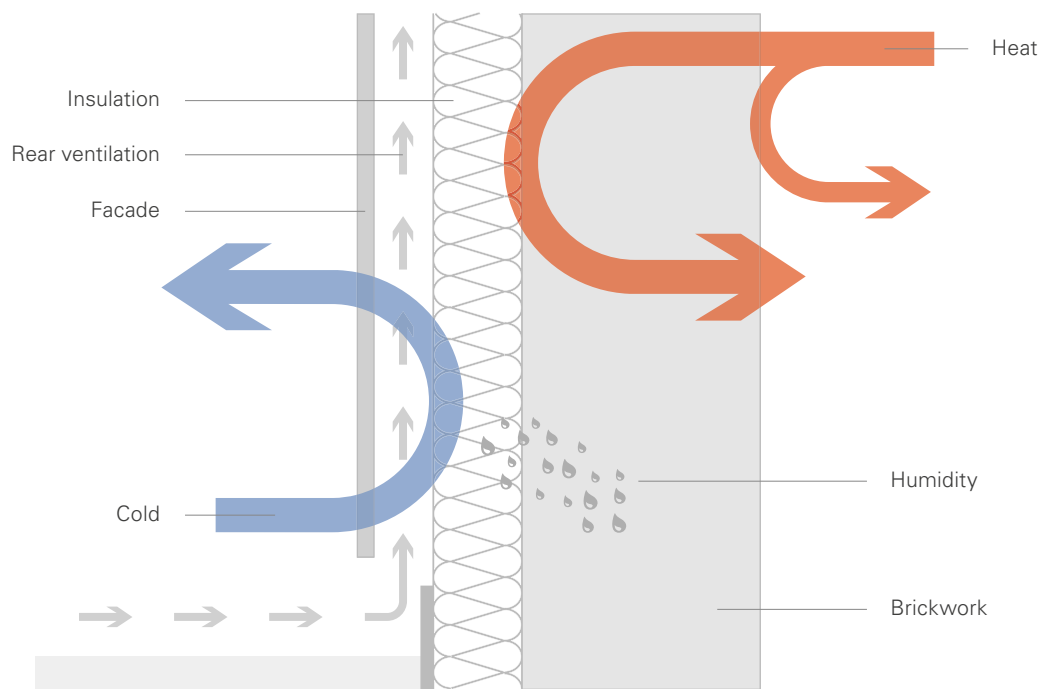

Suspended, rear-ventilated facade system: The constructional separation of thermal insulation and weather protection means that suspended, rear-ventilated facades provide a high degree of design freedom as well as technical and economic efficiency.

# Two systems for all building facades.

## THE FASTENING SYSTEM

The TONALITY facade system consists of facade tiles that are profiled on the back and interlock with vertical aluminium profiles. The vertical joints between the tiles are backed by aluminium joint profiles. TONALITY facade tiles can be used in indoor and outdoor areas for every building type and height. TONALITY facade tiles are also suitable for overhead installation (ceiling lining). TONALITY facade tiles have the building authority approvals Z-10.3-796 for 22 mm tiles and Z-10.3-798 for 26 mm tiles. The maximum spans for the facade tiles in relation to the wind load can be obtained from the specific national technical approvals.

## ADS | ADAPTIVE SYSTEM

Horizontal primary substructure – high flexibility for variable joint design

- Varied designs through open/closed joints, in different colours and with different widths
- Optimum adjustment to static engineering requirements through diverse lengths of support profile

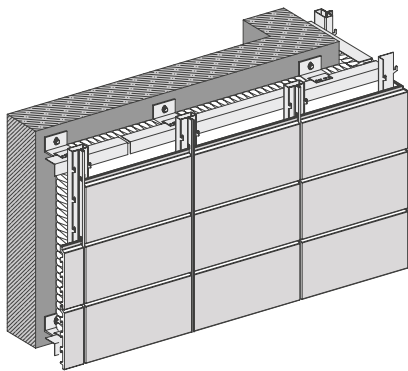

## BAS | BASE CLINCH RAIL SYSTEM

Vertical primary substructure – especially rapid installation for the highest efficiency

- Build-up height from 26 mm – a plus point during facade refurbishment work
- Joint profiles and support profiles in a single element represent fast and easy installation
- Joint profile and support profile are connected using high-tech RIVCLINCH technology

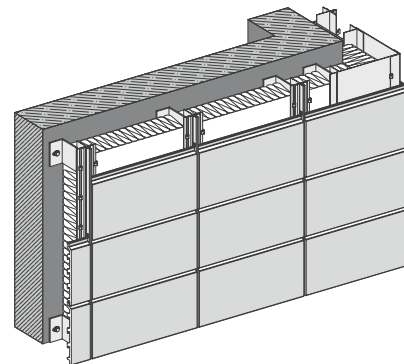

# Top performance of ceramic facades.

## NATURALLY FROM WESTERWALD



A perfect fit, excellent durability and a very good environmental balance are all part of our philosophy. We extract our clay in the Westerwald region – from deposits whose quality and composition is unique in Europe. A one hundred percent natural product made in Germany.

## OUR WEIGHT CLASS



TONALITY facade tiles form a single-layer system of uncompromising quality. This saves resources, reduces the weight considerably and simplifies processing immensely. The lightness of our products is impressive.

## WITH A VIEW TO THE FUTURE



Composite materials, plastics or chemicals? Not in our tiles. The natural advantages of Westerwald clay are so impressive that no additives are needed. This is good for health and for the environment. Recycling and sorted dismantling are easy to achieve.

## WE DO NOT SHUN ANY COMPARISON



TONALITY facade bricks offer advantages in every respect. An exceptionally good environmental balance during production, simple and fast processability – and a durability that makes many other ventilated facade systems look outdated.

## ALL-ROUND DURABILITY



In regards to performance, our TONALITY facade tiles have the potential to be superheroes. Shock and scratch resistant, UV and frost resistant, graffiti resistant, resistant to weather and thermal influences. In other words: Our facade tiles rise to every challenge - and lose neither shape nor colour.

### SAVE INSTALLATION TIME



Thanks to our adaptive and base clinch rail systems, facade installation is stress-free and fast. The low weight of the material does not require a hoist – handling and correct fastening are child’s play. This also applies to the subsequent replacement of tiles, which is possible anywhere and anytime.

### INVISIBLE FASTENING



The TONALITY facade tile system impresses not only with practicality but also because the fastening points are completely invisible after installation. In addition, the joint widths are freely selectable within a range of 2 to 8 mm as standard and, on individual request, even beyond that.

### OUR FACADE TILES FOLLOW YOUR REQUIREMENTS



From top to bottom, from left to right – or however else you want it: The flexible TONALITY systems can be installed without a predetermined mounting direction and can even find a firm hold in curvatures or overhead. And they can be dismantled individually at any time.

### INDIVIDUALITY IS A MATTER OF COURSE



TONALITY offers facade tiles in various colours and designs, even in the basic product line. There are no limits to your individual preferences: Customer requests can easily be realised according to requirements.

### SAFETY IN WORST-CASE SCENARIOS



Both the substructure and the facade tiles withstand the roughest of conditions. As per DIN classification, TONALITY products belong to group A1 - i.e. are non-flammable. Even an earthquake cannot harm the system.

A large, modern indoor swimming pool with a curved, ribbed ceiling and floor-to-ceiling windows overlooking a forest. The ceiling is composed of numerous parallel, curved ribs that create a dynamic, sculptural effect. The pool area is surrounded by a light-colored wooden deck. In the foreground, several lounge chairs are arranged in a row. The water in the pool is clear and blue, reflecting the surrounding environment. The overall atmosphere is bright and airy, with natural light streaming in from the large windows.

**Our reference  
projects**



**ARCHITECT** | Henning Larsen, Copenhagen, DK

**OBJECT** | The Wave Apartments, Vejle, DK

**PRODUCT** | TONALITY® Facades

**COLOUR** | White glossy

**SURFACE** | smooth

**PHOTOGRAPHY** | Jacob Due, DK







# The Wave Apartments



Even before completion of the building, "The Wave" was awarded renowned architectural prizes. Among other things, it received the 2010 LEAF Award (category "Multiple Occupancy").



## A building that is making big waves.

“The Wave” is an exclusive apartment complex whose wave shape reflects both the hilly Jutlandic landscape and the seafaring tradition of the Danish town of Vejle. Five building elements, each with nine floors, convince with unique apartments with phenomenal views. The innovative roof construction blends perfectly into the landscape and impresses with harmonious innovation. This did not go unnoticed by the experts for long: “The Wave” is a reference for timeless Danish aesthetics.

# Vesalius Residential Complex

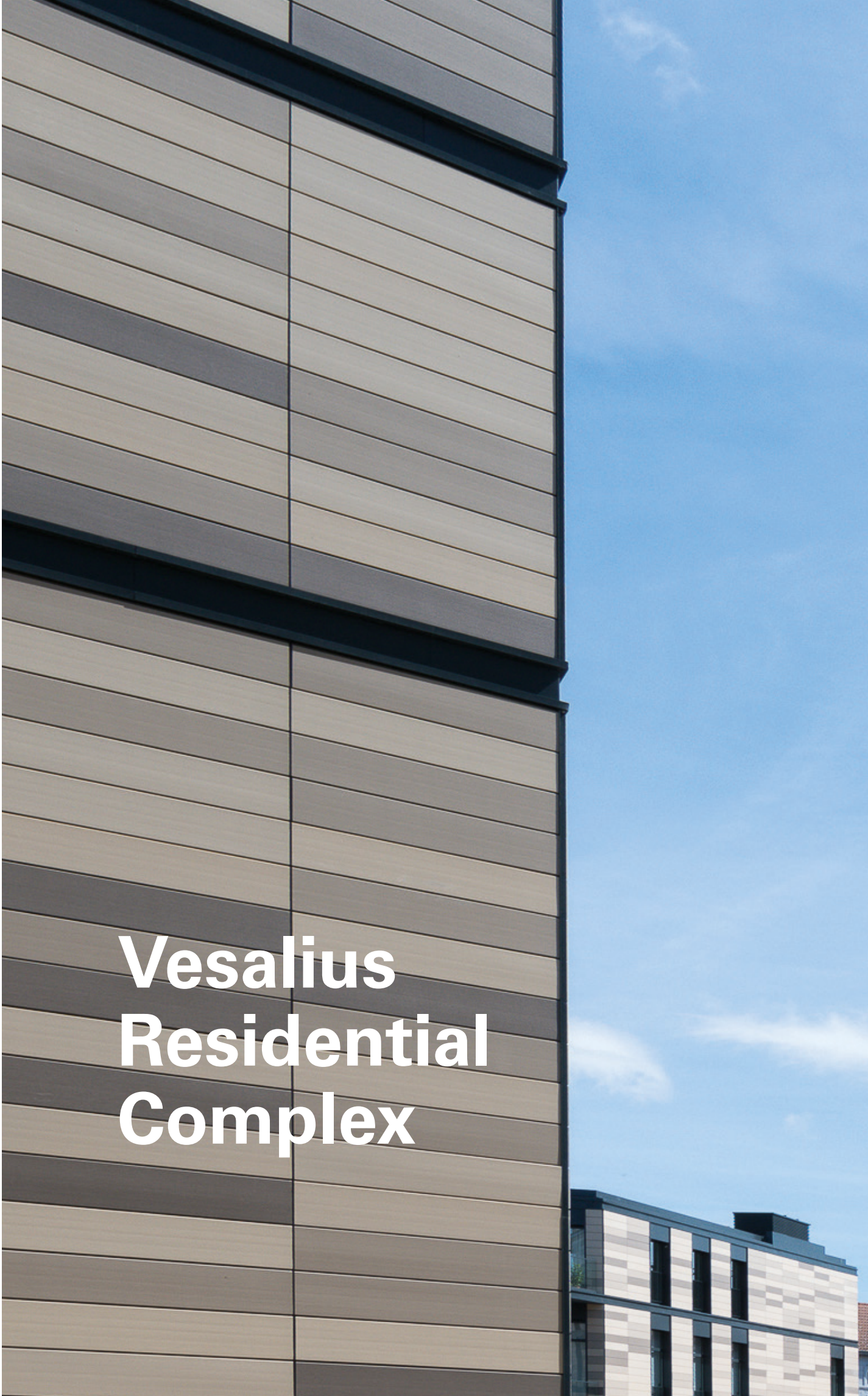

**ARCHITECT** | Jasper-Eyers Architects, BE  
**OBJECT** | Vesalius Residential Complex, Leuven, BE  
**PRODUCT** | TONALITY® Facades  
**COLOUR** | Cream light, Pearl grey, Flint grey  
**SURFACE** | smooth  
**PHOTOGRAPHY** | Marc Detiffe, BE







By integrating existing listed buildings, the whole project became an interplay between new and renovated buildings where the contemporary character embraces historical heritage.

## Really good for the environment.

The “Vesalius” residential complex breathes new life into the old town quarter in Leuven, Belgium. Fired from natural Westerwald clay, the sleek TONALITY facade tiles provide more than just aesthetic value. Providing a colourful and distinctive cladding, the facade tiles ensure long-lasting protection and safety without harming the environment thanks to their durability, low maintenance and non-combustibility. And with their playful earthy-sandy shades, they bring a natural lightness to the urban space.



# Data Centre Office



**ARCHITECT** | WZMH Architects & Urbacon, CA  
**OBJECT** | Data Centre Office, Toronto, Ontario, CA  
**PRODUCT** | TONALITY® Facades & Baguettes  
**COLOUR** | Toscana  
**SURFACE** | smooth  
**PHOTOGRAPHY** | Engineered Assemblies Inc., CA



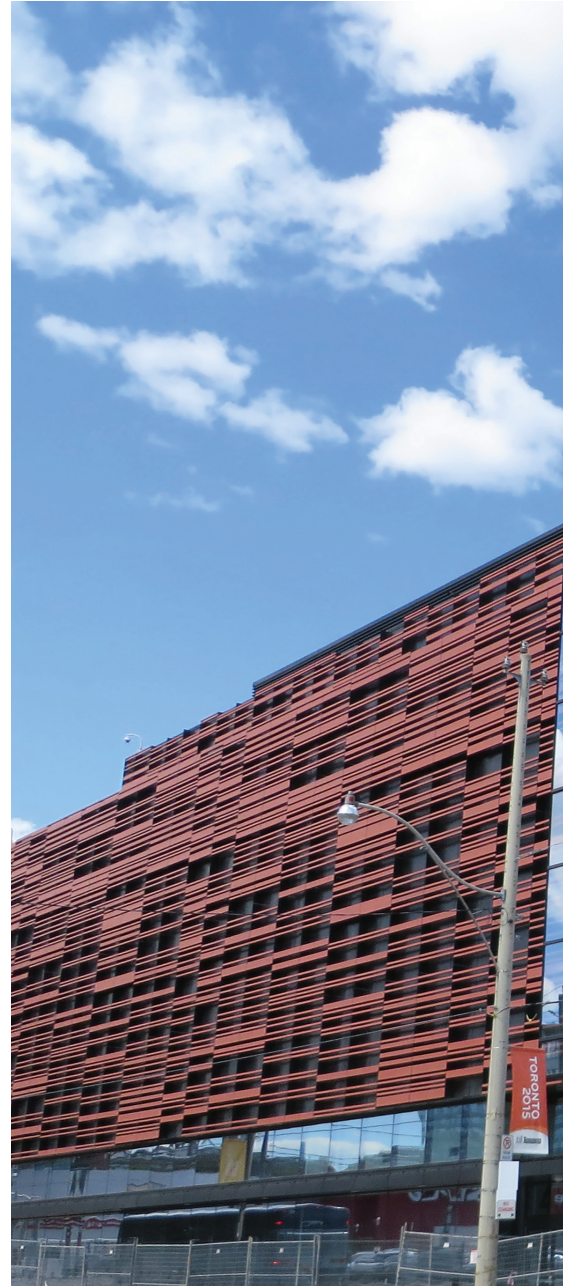

Fascinating from up close, impressively striking from a distance: The light effects of the interplay between baguette facade and tiles.



## A synthesis of vision and clay.

Architecture thrives on the unusual combination of familiar materials, shapes and colours. As is the case with the “Data Centre” in Toronto. What at first appears to be an unusual mix of TONALITY facade tiles and baguettes reveals itself on closer inspection to be a homage to the early computer punched card technology, a forerunner of today’s barcodes. This makes it one of the most innovative buildings in Canada, even beyond the city limits. Here too, we only produced the facade ceramics. Only together with the architect’s vision did it become a unique synthesis.

# Maggie's Centre





**ARCHITECT** | Piers Gough, CZWG Architects LLP, UK

**OBJECT** | Maggie's Centre, Nottingham, UK

**PRODUCT** | TONALITY® Facades

**COLOUR** | Green glossy

**SURFACE** | smooth

**PHOTOGRAPHY** | Tiles International Ltd, Glasgow, UK



## Facades can also get around curves.

The human eye perceives even the most subtle nuances of green. In addition to the 10 million other shades and colours that it can also distinguish. That's why TONALITY attaches great importance to precise colours, shades and surface finishes. Especially when they are individually made to customer specifications, like at "Maggie's Centre" in Nottingham. Because in addition to the wide range of colours, structures and surface finishes, we are experts in special surface and colour designs. Simply because we can.



Impressively vibrant shades of green meet exclusive forms: "Maggie's Centre" in Nottingham and the TONALITY products complement each other perfectly.





**ARCHITECT** | HAL Architects, AU  
**OBJECT** | Toowong Train Station, Queensland, AU  
**PRODUCT** | TONALITY® Facades  
**COLOUR** | White matt, Dark grey and Bright grey  
**SURFACE** | smooth





**Toowong  
Train Station**



## Stylish and confident in Down Under.

In railway stations, TONALITY facade tiles can fully demonstrate their much-appreciated qualities. Bold colours and flexible installation options ensure an individual, stylish and clean look. The glazed surface provides lasting, reliable protection against soiling and graffiti. A dream come true for public buildings and their managers - all over the world.



## GRAFFITI PROTECTION

All glazed surfaces have lasting graffiti protection for the entire life cycle of the product.

# Forfatterhuset Kindergarten



**ARCHITECT** | Cobe, Copenhagen, DK  
**OBJECT** | Forfatterhuset Kindergarten, Copenhagen, DK  
**PRODUCT** | TONALITY® Square  
**COLOUR** | 4 special colours in brickred natural  
**SURFACE** | smooth  
**PHOTOGRAPHY** | Adam Mørk, Copenhagen, DK





Privacy and sun protection cannot be integrated into a facade any more naturally.



## To see and not be seen.

No matter whether you are using Lamella, Baguette or Square elements: They all blend harmoniously into the overall facade design as a solitary design element with metal, ceramic, glass or plaster. Thus they provide discretion on the one hand as well as a pleasant indoor climate in the building through their active sun protection. Impressive architectural design concepts can be realised both on external facades as well as inside buildings using these elements, which are available in numerous dimensions and colours. Whether they are implemented as privacy or sun protection, in all cases they are sure to attract attention.



# Individuality & Colour





# Each facade is like a tailor-made suit.

## CREATIVE DIVERSITY WITHOUT BOUNDS

Your project is unique – and the TONALITY ceramic facade readily conforms. Thanks to modern manufacturing processes and seamless logistics, we are able to react quickly and precisely to your requirements. If you require colours, surface finishes or textures outside the standard range, these will be produced individually for your project. This way, facades can be planned and implemented exactly according to your specifications, just like a tailor-made suit – without compromise.

42

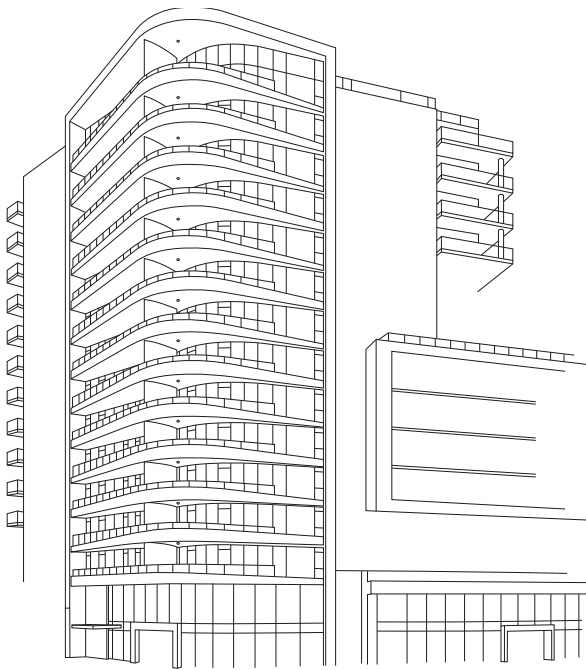

**OBJECT** | Viewstar, Richmond, BC, CAN



**COLOUR** | GE1



**COLOUR** | White glossy

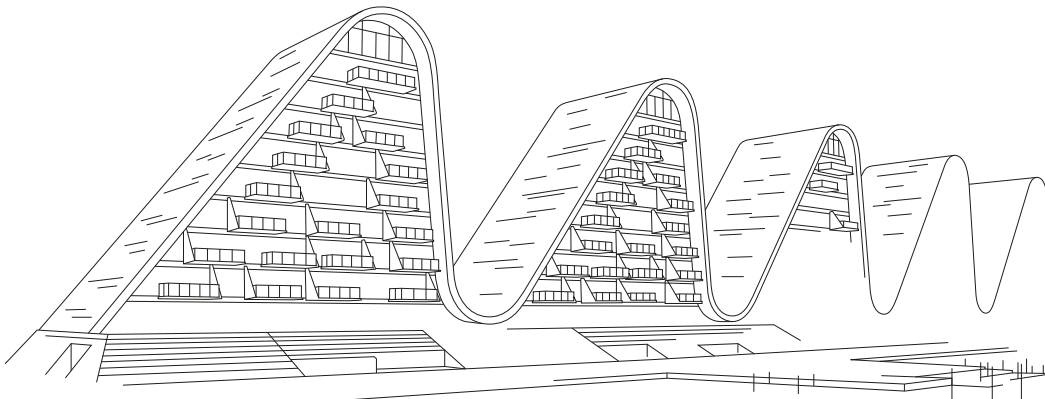

**OBJECT** | The Wave Apartements, Vejle, DK

## CUSTOMISED DESIGNS

TONALITY facade tiles can be produced precisely, to within one millimetre from 300 x 150 mm up to 1,600 x 400 mm. And in endless varieties in between. In combination with the varied standard surface finishes such as smooth, grooved or with pilaster stripes, there are even more possibilities per square metre.

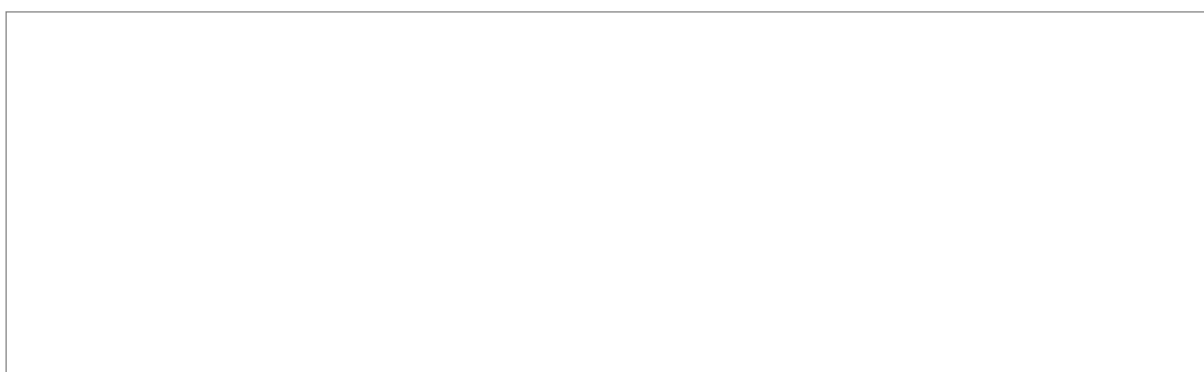

2,000 x 600 mm



300 x 150 mm

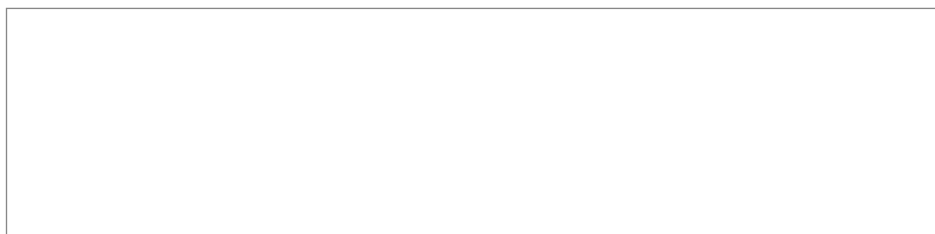

1,600 x 400 mm

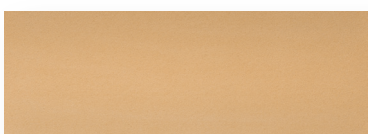

**COLOUR** | Beige

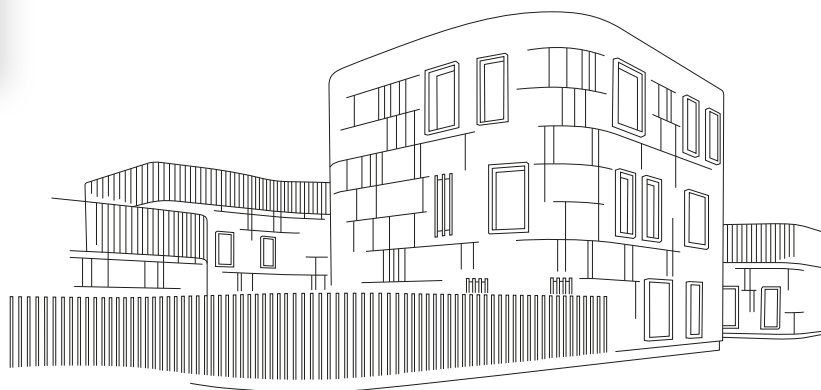

**OBJECT** | Forfatterhuset Kindergarten, Kopenhagen, DK

# Variety on the facade.

## SURFACE FINISH VARIETY

On the surface, more than just a facade. In addition to the wide range of colours and designs, we are experts in surface finishes design. And thanks to the TONALITY sinter firing process, the facade tiles receive an unprecedented even, smooth and dense surface. Choose from a variety of standard surface finishes or discuss your specific design with us. Whether a standard or a special solution, everything at TONALITY is structured.

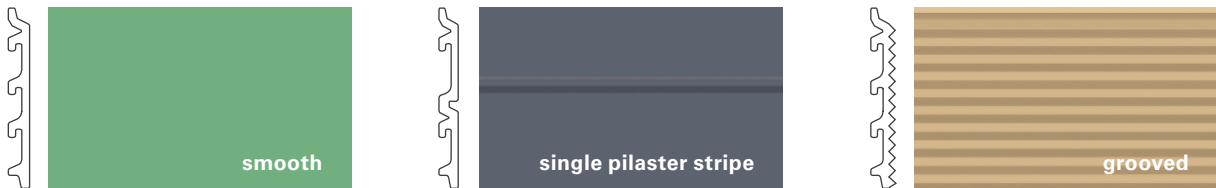

44

## SPECIAL SOLUTIONS

Going new ways is evident also in new colours and surfaces. With its facade tiles, TONALITY aims to make sustainable ideas a tangible reality for new and independent buildings. In order to be able to realise these extraordinary buildings, customised facade tiles are required. To this end, we support architects and planners to realise customised facade tiles.

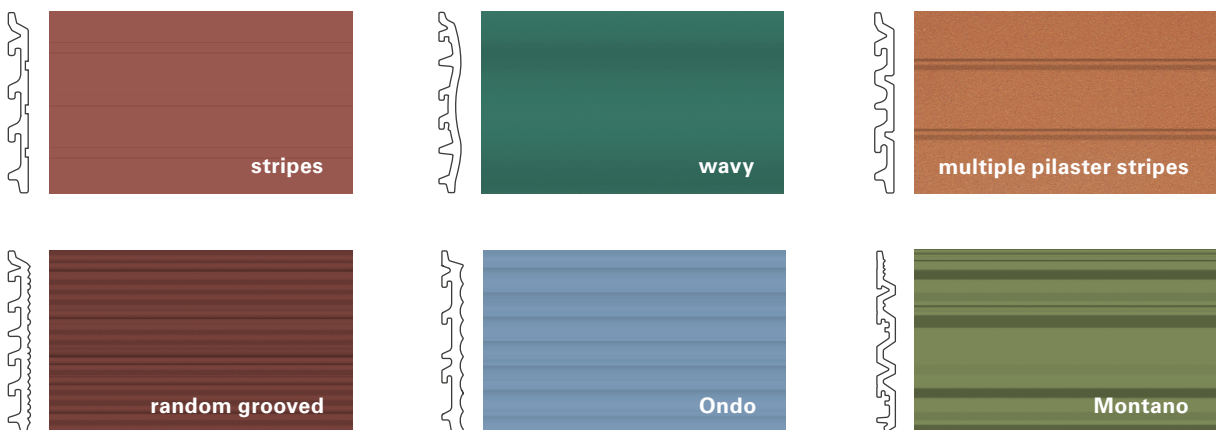

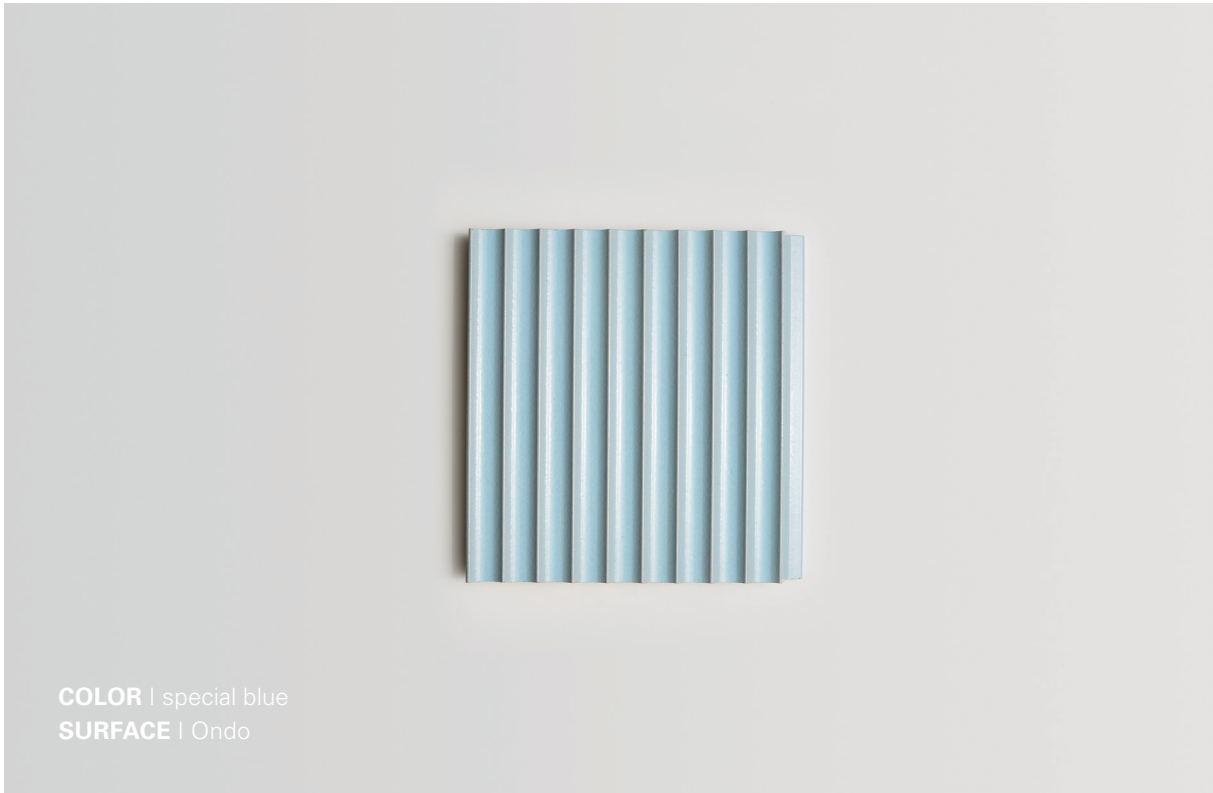

PRIVACY AND SUN PROTECTION

Privacy and sun protection cannot be integrated into a facade any more naturally. No matter whether you are using Lamella, Baguette or Square elements: The ceramic TONALITY privacy and sun protection elements ideally complement the facade tile range and blend harmoniously into the overall facade design as a solitary design element with metal, ceramic, glass or plaster. They can be mounted horizontally and vertically. Thus they provide discretion on the one hand as well as a pleasant indoor climate in the building through their active sun protection.

Lamelle 260

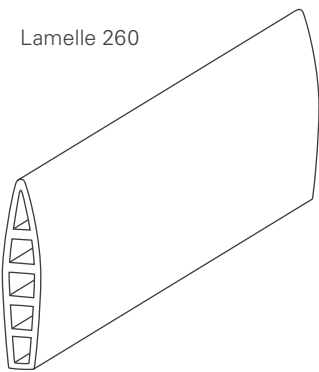

Baguette 150

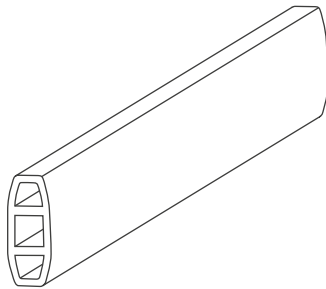

Square 70

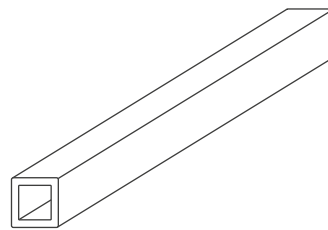

# Contemplate the colours.

## A RICH VARIETY OF DESIGNS INSTEAD OF GREY MONOTONY

TONALITY draws its inspiration from nature. You can choose from more than 50 standard colours and designs. And should your desired colour be missing from this broad spectrum, nearly any shade of colour can be realised as a special colour. Long-lasting colour fastness and UV-resistance are however still standard practice, naturally.









### TONALITY® NATURE COLLECTION

46

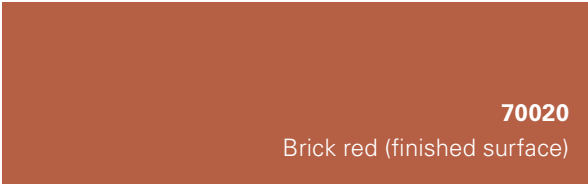
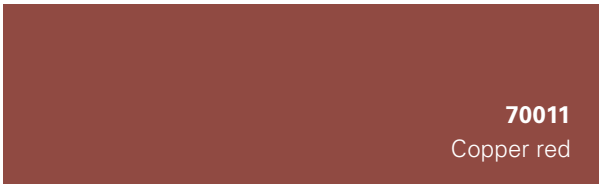
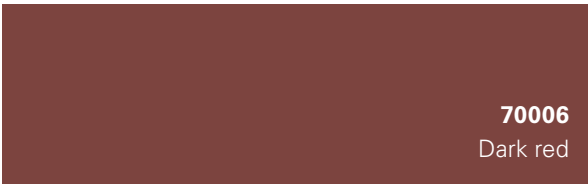
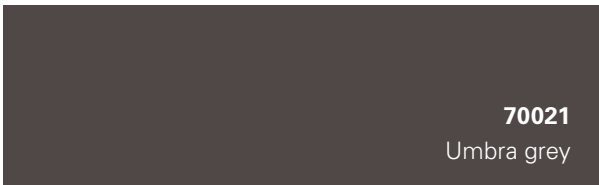

INDIVIDUALITY & COLOUR | Nature Collection

 <p><b>70018</b> White matt</p>	 <p><b>70024</b> Cream light</p>
 <p><b>70022</b> White glossy</p>	 <p><b>70004</b> Cream</p>
 <p><b>70003</b> Light grey</p>	 <p><b>70007</b> Eggshell</p>
 <p><b>70008</b> Bright grey</p>	 <p><b>70002</b> Beige</p>
 <p><b>70014</b> Middle grey</p>	 <p><b>70016</b> Sand</p>
 <p><b>70005</b> Dark grey</p>	

TONALITY® NATURE COLLECTION

 <p><b>70015</b> Pearl grey</p>	 <p><b>70010</b> Flint grey</p>
 <p><b>70017</b> Toscana</p>	 <p><b>70009</b> Bright red</p>
 <p><b>70019</b> Brick red (natural)</p>	 <p><b>70020</b> Brick red (finished surface)</p>
 <p><b>70011</b> Copper red</p>	 <p><b>70006</b> Dark red</p>
 <p><b>70021</b> Umbra grey</p>	 <p><b>70001</b> Anthracite</p>
 <p><b>70025</b> Black matt</p>	 <p><b>70023</b> Black glossy</p>

TONALITY® COLOR COLLECTION

 <p><b>70370</b> TU1</p>	 <p><b>70391</b> VI2</p>
 <p><b>70371</b> TU2</p>	 <p><b>70392</b> VI3</p>
 <p><b>70372</b> TU3</p>	 <p><b>70340</b> BR1</p>
 <p><b>70380</b> GR1</p>	 <p><b>70341</b> BR2</p>
 <p><b>70381</b> GR2</p>	 <p><b>70355</b> BL1</p>
 <p><b>70382</b> GR3</p>	 <p><b>70356</b> BL2</p>
 <p><b>70383</b> GR4</p>	 <p><b>70357</b> BL3</p>
	 <p><b>70358</b> BL4</p>

48



## TONALITY® COLOR COLLECTION

 <b>70350</b> CR1	 <b>70376</b> OK2
 <b>70351</b> CR2	 <b>70360</b> OR1
 <b>70352</b> CR3	 <b>70361</b> OR2
 <b>70365</b> GE1	 <b>70385</b> RO1
 <b>70366</b> GE2	 <b>70386</b> RO2
 <b>70375</b> OK1	 <b>70390</b> VI1

Further colours, designs and surface finishes on request.

Integrated graffiti protection is available for all colours of the TONALITY product lines except 70019 Brick red (natural).



# Sustainability & Vision



# Recycling and circular economy.

FUTURE ALSO MEANS SUSTAINABILITY

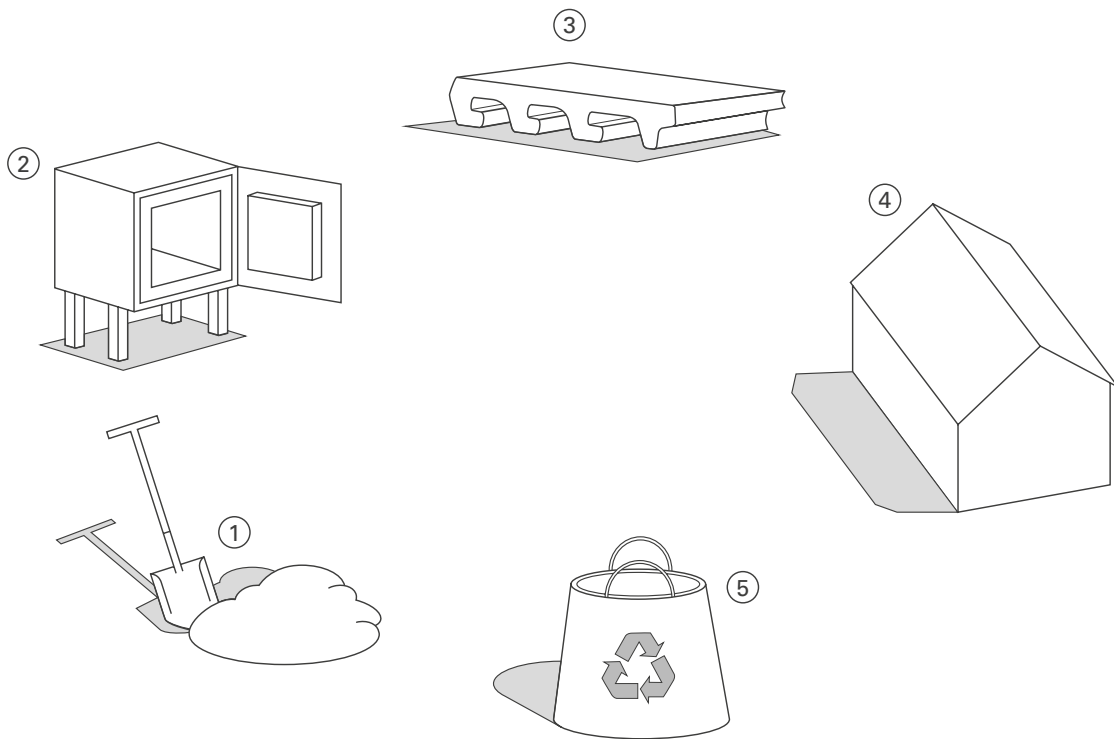

## 1 NATURAL RAW MATERIAL

The remarkable properties of clay have been known since ancient times. The discovery of clay ceramics made using the special plasticity of clay material dates from 10,000 - 8,000 BC. Thus, clay is among the oldest natural materials used by mankind. Clays are weathering and erosion products of the earth's crust. They occur in continental and maritime environments. Their diversity depends on the physico-chemical formation conditions, which give rise to a wide range of properties and thus the many uses of the clays. The first-class clays used for TONALITY are excavated in the Westerwald. They are among the world's finest clays and are famous for their special purity.

## 2 TONALITY® HIGH TEMPERATURE FIRING

TONALITY facade tiles are produced in cutting-edge production facilities using the vacuum extrusion process, then dried in a four-storey roller dryer in a particularly gentle manner and fired at high temperatures. In the innovative TONALITY production process, the raw material clay is homogenised and dried, processed into the finest powdered clay and prepared in finely graded mixing ratios. The products are then fired at high temperatures of over 1,200°C. Due to the high-quality raw materials and the high firing temperature, sintering occurs during firing. This ensures material density and a smooth surface finish.

## 3 THE TILE OF THE FUTURE

Installation has never been so easy: position it, hang it in place, you're done. No clips, no visible fasteners, no stress. And whether you work from bottom to top, from right to left or top to bottom, both the adaptive system (ADS) as well as the base clinch rail system (BAS) are completely flexible. Even during subsequent replacement of damaged tiles. And for safety reasons, an integrated dismantling safety device can also be activated. Flexibility can be fast.

## 4 FACADE FOR INDOORS AND OUTDOORS

The rear-ventilated curtain facade can be used in indoor and outdoor areas for every building type and height. The TONALITY facade system has been certified in accordance with DIN 18516 of the German Institute for Building Technology (DIBT) (national technical approvals Z-10.3-796 and Z-10.3-798). TONALITY products can provide privacy and sun protection.

## 5 OUR ENVIRONMENTAL PHILOSOPHY

In an innovative recycling plant, returned building site materials and reclaimed ceramics are reprocessed for new purposes or used for the development of new products. Broken tiles are used in green roofs or for road construction. This means that tiles from TONALITY and LEIPFINGER-BADER are treated as what they are: a recyclable material.

## Visions that improve construction.

In close cooperation with our market partners, we develop and produce innovative ceramic facade tiles in Weroth, Germany, which meet the highest standards in terms of aesthetics, fire safety, durability and processability. With LEIPFINGER-BADER at our side, we will further strengthen the area of research and development in the future. After all, the trademark of the Lower Bavarian tile manufacturer is their innovative strength.

Product development and advancement was and is an important part of the company's success, as are projects in the areas of digitalisation, recycling and logistics. We promote numerous research projects with institutions, universities and partners and develop the best solutions for construction, people and nature. We make construction even more ecological, energy-efficient, fast and safe.

Modern buildings and nature in harmony: Architecture of the future shows how modern constructions and vegetation can be aesthetically reconciled. The best example of this is the research on green facades.







TONALITY GmbH  
In der Mark 100  
D-56414 Weroth

Tel: +49 6435 90999-0  
info@tonality.de



[www.tonality.de](http://www.tonality.de)